

INDUSTRIAL BLUETOOTH™

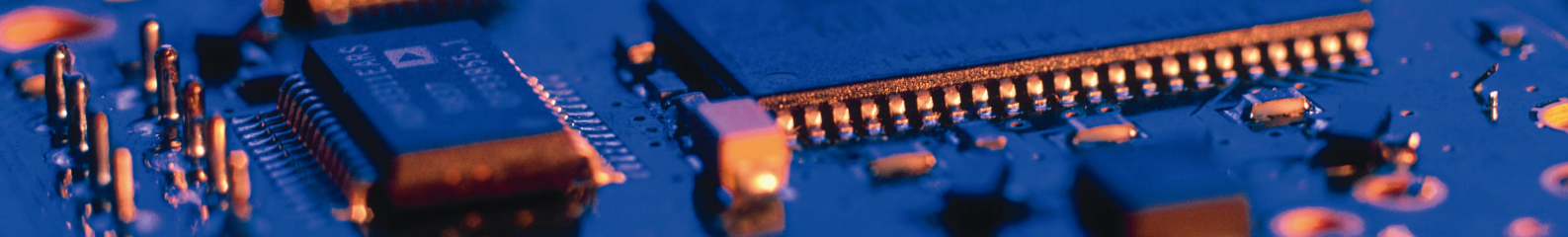

Serial Port Adapter™

Product Guide 3.1

connectBlue

Serial Port Adapter™

Product Guide

Copyright © 2006 connectBlue AB

The contents of this document can be changed by connectBlue AB without prior notice and do not constitute any binding undertakings from connectBlue AB. connectBlue AB is not responsible under any circumstances for direct, indirect, unexpected damage or consequent damage that is caused by this document.

All rights reserved.

Release: 0801

Document version: 3.1

Document number: cBProduct-0610-05 (6)

Printed in Sweden

Trademarks

Registered trademarks from other companies are: Bluetooth is a trademark owned by the Bluetooth SIG, Inc. Microsoft™, Windows™, Windows NT™, Windows 2000™, Windows CE™, Windows ME™, Windows XP™ are registered trademarks from Microsoft Corporation

Contents

1	INTRODUCTION	8
1.1	RELATED DOCUMENTS.....	9
1.2	WHAT IS BLUETOOTH WIRELESS TECHNOLOGY?.....	9
1.3	HOW CAN I USE MY SERIAL PORT ADAPTER?.....	10
1.4	GETTING STARTED	10
2	INSTALLATION	11
2.1	OEM SERIAL PORT ADAPTERS	11
2.2	SERIAL PORT ADAPTER 312I.....	11
2.2.1	<i>Mounting</i>	11
2.2.2	<i>Power Supply</i>	12
2.2.3	<i>RS232</i>	12
2.2.4	<i>Buttons and LED</i>	13
2.3	RUGGED SERIAL PORT ADAPTER 333S	14
2.3.1	<i>Mounting</i>	14
2.3.2	<i>Power Supply</i>	15
2.3.3	<i>RS232</i>	15
2.3.4	<i>RS422</i>	16
2.3.5	<i>RS485</i>	18
2.3.6	<i>Button and LED</i>	18
3	REGULATORY INFORMATION.....	20
3.1	FCC STATEMENT	20
3.1.1	<i>RF-Exposure Statement</i>	20
3.1.2	<i>Antenna</i>	20
3.1.3	<i>Caution</i>	21
3.2	DECLARATION OF CONFORMITY	22
4	BLUETOOTH QUALIFICATION	23
5	ADDITIONAL INFORMATION	25
5.1	GUIDELINES FOR EFFICIENT AND SAFE USE	25
5.1.1	<i>Product Care</i>	25
5.1.2	<i>Radio Frequency Exposure</i>	25
5.1.3	<i>Electronic Equipment</i>	27
5.1.4	<i>Potentially Explosive Atmospheres</i>	27

5.1.5	<i>Power Supply</i>	27
5.2	TROUBLESHOOTING.....	27
5.3	TECHNICAL SPECIFICATIONS.....	28
5.3.1	<i>Environmental</i>	28
5.3.2	<i>Certifications and Compliance</i>	29
5.3.3	<i>Type Approval</i>	29
5.3.4	<i>Radio Output Power</i>	29
5.3.5	<i>Power Supply</i>	29
5.3.6	<i>Serial Interface</i>	29
5.3.7	<i>Housing</i>	29
5.3.8	<i>Dimensions</i>	30

1 Introduction

Congratulations on your purchase of a connectBlue Serial Port Adapter™. The Serial Port Adapter can be used as a component in many types of systems allowing them to communicate wirelessly with other Bluetooth products such as PC-cards, laptops, handheld computers, mobile phones and other Serial Port Adapters. The Serial Port Adapter is a suitable component in new products as well as in existing products. A wide range of models is available to cover a wide range of usage areas.

This manual covers all the boxed Serial Port Adapters from connectBlue. It especially focuses on how to mount the Serial Port Adapter and how to use the connectors of the Serial Port Adapter.

Brief overview of the features of the different Serial Port Adapter models:

Serial Port Adapter 312i Plastic housing, short range (7 dBm), RS232 (DSUB), internal antenna, 5 VDC power supply. AT command interface.



Rugged Serial Port Adapter 333s Metal housing (IP65), long range (20 dBm), RS232/RS422/RS485 (DSUB), stub antenna, 8-30 VDC power supply. AT and ECI command interface.



Please read the chapter “Guidelines for Efficient and Safe use” before using your Serial Port Adapter.

1.1 Related Documents

- The **Serial Port Adapter Product Guide**, this document, contains information on how to use the Serial Port Adapter. Study this document before moving on to the others.
- The **Serial Port Adapter AT Commands** document contains a description of the AT commands supported in the Serial Port Adapter. It also contains information on how to use the AT commands to create Bluetooth applications.
- The **OEM Serial Port Adapter Electrical & Mechanical Datasheets** contains important information about the OEM Serial Port Adapter. Read this document if you are using the OEM Serial Port Adapter.
- The **Bluetooth Enabler Development Kit** is required when using the ECI functionality embedded in the Serial Port Adapter (only available on OEMSPA333i/x and RSPA333s).
 - The **ECI Protocol Specification** contains detailed descriptions of the ECI protocol.

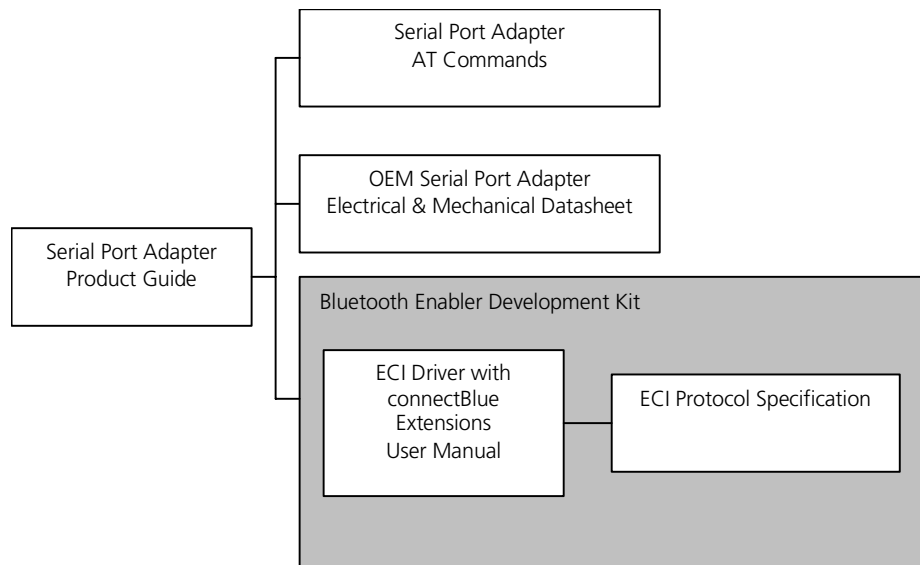

Picture 1. Serial Port Adapter documents

1.2 What is Bluetooth Wireless Technology?

Bluetooth allows compatible portable and stationary communications devices to communicate without using cables. The technology is based on a radio link that offers fast and reliable transmission of voice and data information. It doesn't require a line-of-sight connection in order to establish and maintain communication. The Bluetooth wireless

technology uses a globally available frequency range intended to ensure communication compatibility worldwide. Bluetooth is available in mobile phones, laptops, handheld computers, industrial devices, cars, and more.

1.3 How can I use my Serial Port Adapter?

Your Serial Port Adapter communicates with its host system using RS232, RS422, or RS485.

Once connected to its host system and configured, the Serial Port Adapter can communicate, using Bluetooth, with a wide range of other Bluetooth enabled devices such as other Serial Port Adapters, mobile phones, handheld computers and laptops.



Picture 2. The Serial Port Adapter connected to the controller communicates wirelessly with a Bluetooth enabled Laptop.

The Serial Port Adapter can initiate as well as accept connections to and from other Bluetooth devices. When initiating a connection to another device, the Serial Port Adapter acts as a client. When accepting a connection from another device, the Serial Port Adapter acts as a server. In most cases the Serial Port Adapter communicates with one Bluetooth device at a time, but in some variants it is possible for the Serial Port Adapter to simultaneously communicate with several Bluetooth devices. This feature is called Wireless Multidrop™. For further details please read the Serial Port Adapter AT Command Specification or the ECI Protocol Specification.

1.4 Getting Started

Before using your Serial Port Adapter you must:

- Install your Serial Port Adapter. For more information, see chapter 2.
- Configure your Serial Port Adapter. For more information, please read the Serial Port Adapter AT Command Specification or the ECI Protocol Specification. It is also possible to use the Serial Port Adapter Wizard for easy configuration.

2 Installation

Before using your Serial Port Adapter it must be connected to its host system and it must be connected to a power supply. The installation differs slightly from model to model.

This chapter describes how to install your Serial Port Adapter.

2.1 OEM Serial Port Adapters

If you are using the OEM Serial Port Adapter please refer to the "Electrical & Mechanical Datasheet" for the specific model, for installation instructions. The latest "Electrical & Mechanical Datasheet" can be downloaded from www.connectblue.se.

2.2 Serial Port Adapter 312i

2.2.1 Mounting

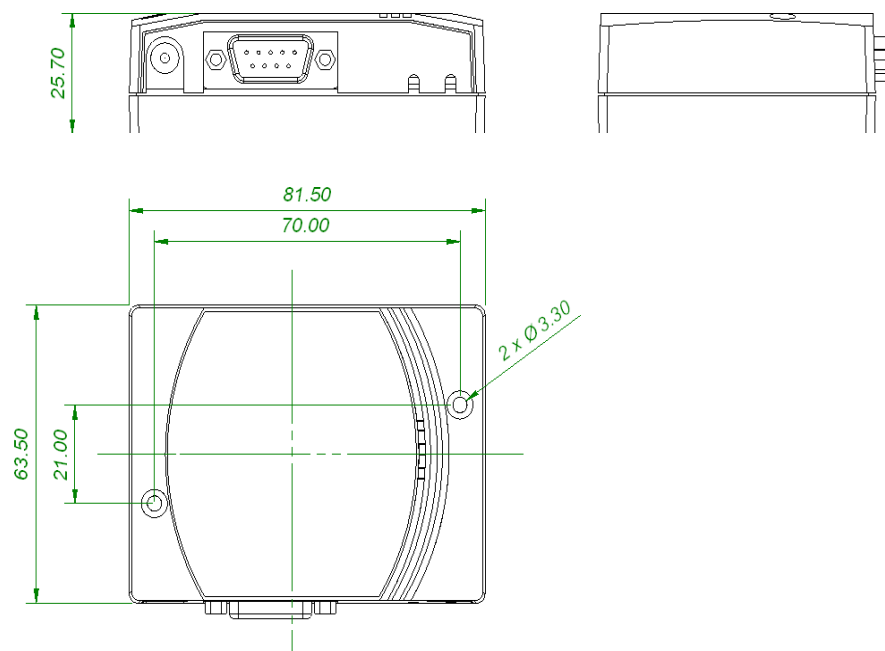

Picture 3. The Serial Port Adapter can be mounted using the mounting holes.

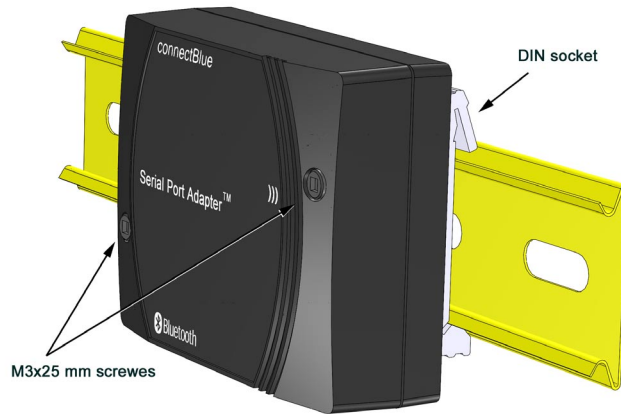

Picture 4. The Serial Port Adapter can be mounted on a DIN socket using the mounting holes. Note that the Serial Port Adapter 312i has internal antenna. Therefore it cannot be mounted inside a shielded enclosure.

2.2.2 Power Supply

If you are not using the power adapter provided with the product or if there is none provided you must use a DC plug 2,1 mm centerpin (-) connector.

The product shall have a power supply of 5 VDC, min 200 mA on the power connector.

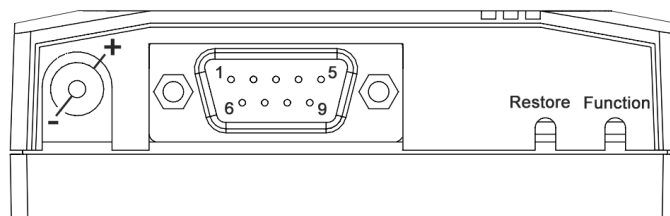

Picture 5. DC plug 2,1 mm centerpin (-) and 9-pin DSUB male.

2.2.3 RS232

RS232 male 9-pin DSUB:

- Pin 1: NC, not connected
- Pin 2: RD, input, receive data
- Pin 3: TD, output, transmit data

- Pin 4: DTR, output, data terminal ready
- Pin 5: GND, ground
- Pin 6: DSR, input, data set ready
- Pin 7: RTS, output, request to send
- Pin 8: CTS, input, clear to send
- Pin 9: NC, not connected

The model is designed to operate as a DTE (Data Terminal Equipment). When connecting the Serial Port Adapter to a DCE (Data Communication Equipment), e.g. a modem, a regular modem cable, straight cable, shall be used. When connecting the Serial Port Adapter to another DTE, e.g. a PC, a crossover serial cable must be used. The crossover cable must have TD and RD crossed (pins 2-3 and 3-2), RTS and CTS crossed (pins 7-8 and 8-7) and optionally DTR and DSR crossed (pins 4-6 and 6-4).

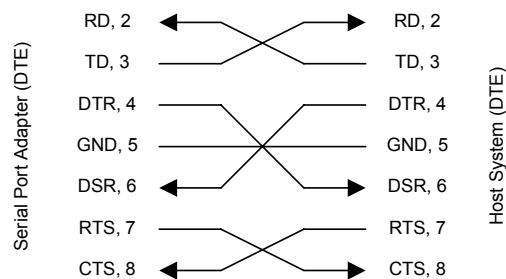

Picture 6. Crossover cable

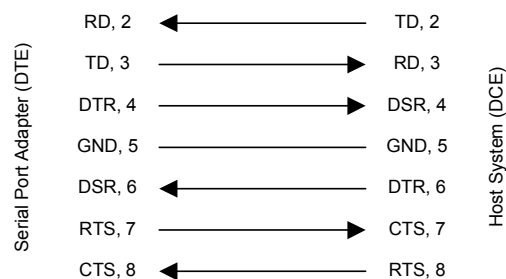

Picture 7. Straight cable

2.2.4 Buttons and LED

If the *restore button* (see Picture 5) is pressed during power on, the default serial settings as well as the default escape sequence are restored. If the *function button* (see Picture 5) is pressed and a remote peer is configured for "external connect" the connect attempt is initiated. See AT Command Specification for further details.

The status LED uses the following color indications.

- **Green:** The current mode is data mode and no connection attempt is in progress.
- **Orange:** The current mode is AT mode.
- **Purple:** A connection attempt is in progress.
- **Blue:** A connection is currently active.
- **Blue Blinking:** A connection is active and data is transmitted or received over air.
- **Red Blinking:** Buffer overflow, parity or framing error detected on the UART.

2.3 Rugged Serial Port Adapter 333s

2.3.1 Mounting

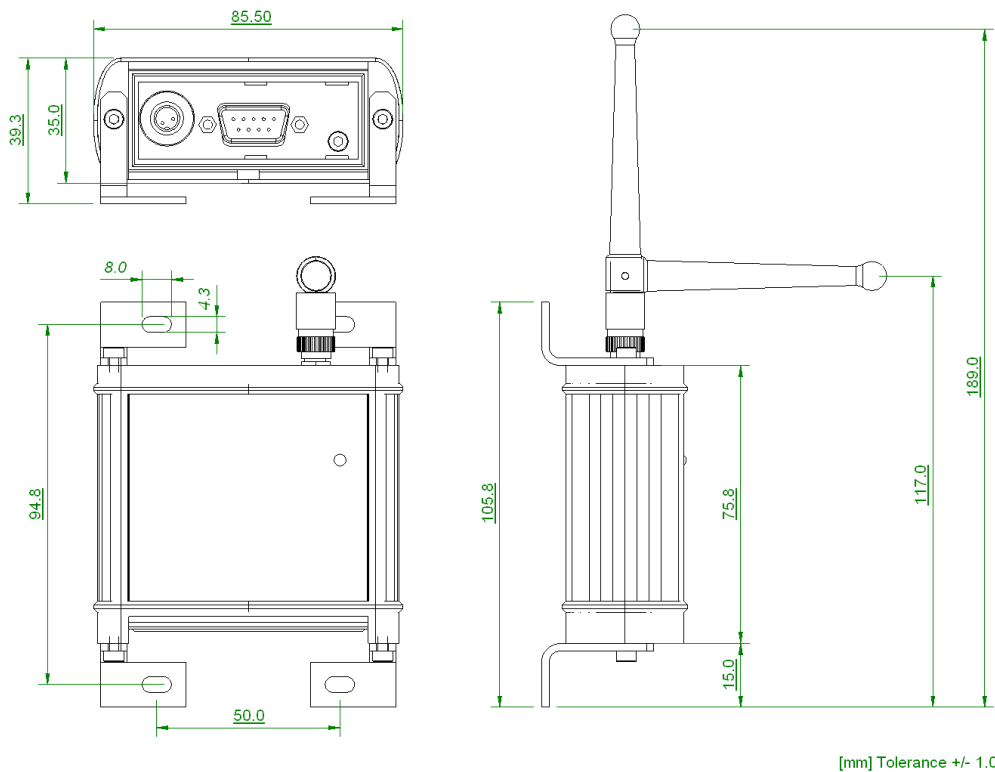

Picture 8. The Serial Port Adapter can be mounted using the mounting holes.

Rugged Serial Port Adapter 333s must only be used with the antenna provided with the product. Using another antenna will violate the regulatory type approval. The product cannot be mounted inside a shielded enclosure.

2.3.2 Power Supply

The product shall have a power supply of 8-30 VDC, 1 W on pin 1 (-) and 2 (+) on the power connector. Use a female power connector 712 series from Binder.

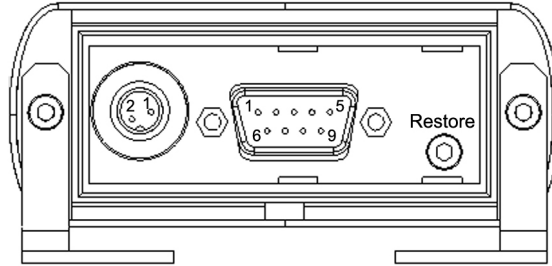

Picture 9. DSUB serial connector (male).

2.3.3 RS232

This model supports RS232 with a male 9-pin DSUB:

- Pin 1: NC, not connected
- Pin 2: RD, input, receive data
- Pin 3: TD, output, transmit data
- Pin 4: DTR, output, data terminal ready
- Pin 5: GND, ground
- Pin 6: DSR, input, data set ready
- Pin 7: RTS, output, request to send
- Pin 8: CTS, input, clear to send
- Pin 9: NC, not connected

The model is designed to operate as a DTE (Data Terminal Equipment). When connecting the Serial Port Adapter to a DCE (Data Communication Equipment), e.g. a modem, a regular modem cable, straight cable, shall be used. When connecting the Serial Port Adapter to another DTE, e.g. a PC, a crossover serial cable must be used. The crossover cable must have TD and RD crossed (pins 2-3 and 3-2), RTS and CTS crossed (pins 7-8 and 8-7) and optionally DTR and DSR crossed (pins 4-6 and 6-4).

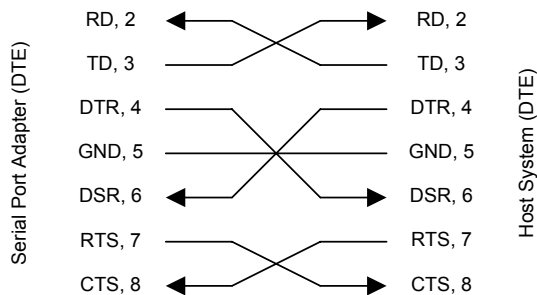

Picture 10. Crossover cable

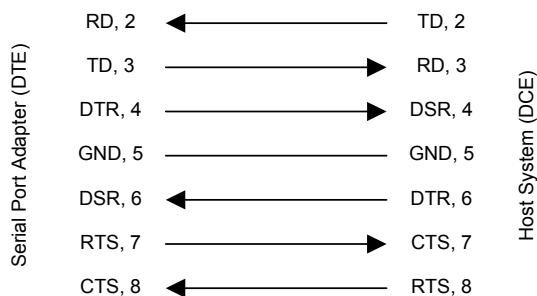

Picture 11. Straight cable

2.3.4 RS422

In this model, the same DSUB connector is used when using RS232, RS422 and RS485. However, in the case of RS422 and RS485, the pins have different meanings compared to RS232. For details please read the AT command specification document.

In the RS422 case, the following pinning is used:

- Pin 1: R-, input, receiver
- Pin 2: T-, output, transmitter
- Pin 3: NC, not connected
- Pin 4: NC, not connected
- Pin 5: NC, not connected
- Pin 6: R+, input, receiver
- Pin 7: NC, not connected
- Pin 8: T+, output, transmitter
- Pin 9: NC, not connected

For four-wire RS422 multidrop, the following connection setup shall be used:

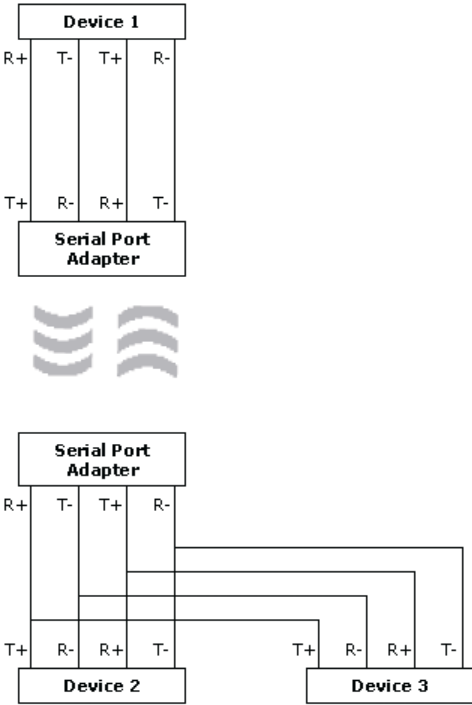

Picture 12. Four-wire RS422 connection setup

Note: The definition of R+/R-,T+/T- may vary between manufacturers.

2.3.5 RS485

In the case of RS485, the same pinning as for RS422 is used, except that pins T- and R- must be connected externally and pins T+ and R+ must be connected externally to produce the signals T-/R- and T+/R+. For two-wire RS485 multidrop, the following connection setup shall be used:

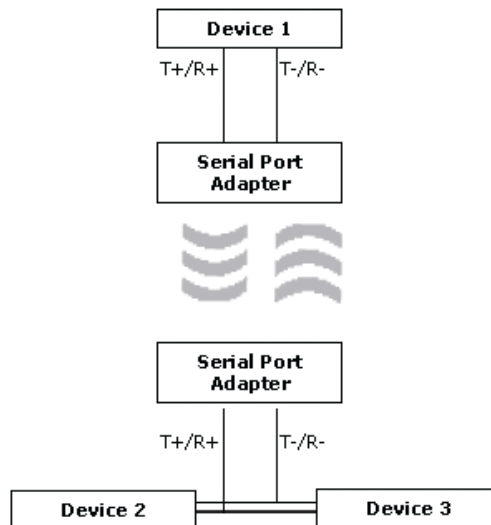

Picture 13. Two-wire RS485 connection setup

2.3.6 Button and LED

If the *restore button* (see Picture 9) is pressed during power on, the default serial settings as well as the default escape sequence are restored.

The status LED uses the following color indications.

- **Green:** The current mode is data mode and no connection attempt is in progress.
- **Orange:** The current mode is AT mode.
- **Purple:** A connection attempt is in progress.
- **Blue:** A connection is currently active.
- **Blue Blinking:** A connection is active and data is transmitted or received over air.
- **Red Blinking:** Buffer overflow, parity or framing error detected on the UART.

3 Regulatory Information

3.1 FCC Statement

This device complies with Part 15 of the FCC Rules. Operation is subject to the following two conditions: (1) this device may not cause harmful interference, and (2) this device must accept any interference received, including interference that may cause undesired operation.

NOTE: This equipment has been tested and found to comply with the limits for a Class B digital device, pursuant to Part 15 of the FCC Rules. These limits are designed to provide reasonable protection against harmful interference in a residential installation. This equipment generates, uses and can radiate radio frequency energy and, if not installed and used in accordance with the instructions, may cause harmful interference to radio communications. However, there is no guarantee that interference will not occur in a particular installation. If this equipment does cause harmful interference to radio or television reception, which can be determined by turning the equipment off and on, the user is encouraged to try to correct the interference by one or more of the following measures:

- Reorient or relocate the receiving antenna
- Increase the separation between the equipment and receiver
- Connect the equipment into an outlet on a circuit different from that to which the receiver is connected

Consult the dealer or an experienced radio/TV technician for help

3.1.1 RF-Exposure Statement

This transmitter **MUST** have a separation distance of at least 20 cm between the antenna and the body of the user or nearby persons, excluding hands, wrists, feet, and ankles.

If the radio is installed in a laptop display, transmission **MUST** be prevented if the lid is closed to ensure that the minimum distance of 20 cm between the user and the transmitting antenna is maintained.

Any notification to the end user of installation or removal instructions about the integrated radio is **NOT** allowed.

3.1.2 Antenna

The antenna is fixed and cannot be removed or replaced by the user.

3.1.3 Caution

Any changes or modifications NOT explicitly APPROVED by connectBlue AB could cause the device to cease to comply with FCC rules part 15, and thus void the user's authority to operate the equipment.

3.2 Declaration of Conformity



We, **connectBlue AB**, of
Norra Vallgatan 64 3V
SE-211 22 Malmö, Sweden

declare under our sole responsibility that our products:

cB-RSPA333s (cB-0144), cB-SPA312i (cB-0090)

to which this declaration relates, conforms to the following product specifications:

R&TTE Directive 1999/5/EC

EN 300 328 V1.6.1 (2004-11)

EMC Directive: 89/336/EEC

EN 301 489-1 V1.4.1 (2002-08)

EN 301 489-17 V1.2.1 (2002-08)

EN 61000-6-2 (2001)

Safety Compliance

EN 60950-1:2001 and/or IEC 60950-1:2001 (1st Edition)

EN 60950-1/A11:2004 + Corrigendum:2004

Medical Electrical Equipment

IEC 60601-1-2 (2001)

17/07/2006 Malmö, Sweden

Mats Andersson

CTO of connectBlue AB

If an RSPA333s or SPA312i is used within EU a notification must be made to each of the national authorities responsible for radio spectrum management of the intention to place radio equipment that uses frequency bands whose use is not harmonized throughout the EU, on its national market.

More information at: <http://europa.eu.int/comm/enterprise/rtte/gener.htm>

4 Bluetooth Qualification

All Serial Port Adapter models have been qualified according to the Bluetooth specification.

Module	Bluetooth specification	QPLN reference	List date
SPA312i	2.0	B02690	2005-11-15
RSPA333s	2.0	B03344	2006-07-18

The following Bluetooth profiles are supported (covered functionality):

- Generic Access Profile
- Serial Port Profile
- Dial-up Networking Profile
- LAN Access Profile¹

When creating end products based on the Serial Port Adapter the following applies:

- The end product does not have to be re-qualified.
- The end product or the end product documentation shall make the following information available: "This product contains a Bluetooth qualified product (QPLN reference)".
- The Bluetooth Trademark may be placed on the end product (requires Bluetooth SIG membership, for more information see www.bluetooth.com).
- The Bluetooth Trademark may be used in material related to the end product (requires Bluetooth SIG membership, for more information see www.bluetooth.com).

For more information please visit www.connectblue.se.

¹ LAN profile only supported in RSPA333s.

5 Additional Information

5.1 Guidelines for Efficient and Safe Use

Read this information before using your Serial Port Adapter.

For any exceptions, due to national requirements or limitations, when using your Serial Port Adapter, please visit www.bluetooth.com.

Note: Changes or modifications to the product not expressly approved by connectBlue AB will void the user's authority to operate the equipment.

5.1.1 Product Care

- Do not expose your product to liquid or moisture.
- Do not expose your product to extreme hot or cold temperature (see Technical Specification for further information)
- Do not expose your product to lit candles, cigarettes, cigars, open flames, etc.
- Do not drop, throw or try to bend your product since rough treatment could damage your product.
- Do not attempt to disassemble your product. Doing so will void warranty. The product does not contain consumer serviceable or replaceable components. Service should only be performed by connectBlue AB.
- Do not paint your product as the paint could prevent normal use.
- If you will not be using your product for a while, store it in a place that is dry, free from damp, dust and extreme heat and cold.
- The clearance and creepage distances required by the end product must be withheld when the module is installed.
- The cooling of the end product shall not negatively be influenced by the installation of the module when the module is installed.

5.1.2 Radio Frequency Exposure

The Serial Port Adapter contains a small radio transmitter and receiver. During communication with other Bluetooth products the Serial Port Adapter receives and transmits radio frequency (RF) electromagnetic fields (microwaves) in the frequency range 2400 to 2500 MHz. The output power of the radio transmitter is very low.

When using the Serial Port Adapter, you will be exposed to some of the transmitted RF energy. This exposure is well below the prescribed limits in all national and international RF safety standards and regulations.

5.1.3 Electronic Equipment

Most modern electronic equipment, for example, in hospitals and cars, is shielded from RF energy. However, certain electronic equipment is not. Therefore:

Note: This equipment emits RF energy in the ISM (Industrial, Scientific, Medical) band. Please insure that all medical devices used in proximity to this device meet appropriate susceptibility specifications for this type of RF energy.

5.1.4 Potentially Explosive Atmospheres

Turn off your electronic device when in any area with potentially explosive atmosphere. It is rare, but your electronic device could generate sparks. Sparks in such areas could cause an explosion or fire resulting in bodily injury or even death.

Areas with a potentially explosive atmosphere are often, but not always, clearly marked. They include fuelling areas, such as petrol station, below deck on boats, fuel or chemical transfer or storage facilities, and areas where the air contains chemicals or particles, such as grain, dust, or metal powders.

5.1.5 Power Supply

The Serial Port Adapter must be supplied by a limited power source according to EN 60950-1.

- Connect your power supply only to designated power-sources as marked on the product.
- Make sure all cords and cable are positioned so that they will not be stepped on, tripped over or otherwise subject to damage or stress.
- To reduce risk of electric shock, unplug the unit from any power source before attempting to clean it.

5.2 Troubleshooting

This section lists some problems that you might encounter while using your Serial Port Adapter.

1. I cannot connect. The data I send to the Serial Port Adapter does not arrive at the remote device.
 - Make sure that you have connected power to your Serial Port Adapter. The LED indicator should emit a green light when powered up, being ready to send and receive data.
 - Your Serial Port Adapter is not configured to use the same serial settings (e.g. baud rate) as your host system. Use the configuration wizard to set the correct baud rate.

-
- You have configured your Serial Port Adapter to act as a client but you have not selected a server device to connect to. Select a server device using the configuration wizard.
 - Your Serial Port Adapter is too far away from the selected server device. Move the Serial Port Adapter closer to the server device.
 - You are not using the correct Bluetooth profile. Your Serial Port Adapter must be configured to use the same profile as the device you want to communicate with.
 - The remote device is not in connectable mode. If the server device is another Serial Port Adapter use the configuration wizard to set the device in connectable mode. If the device is another Bluetooth device, consult the manual for that device to set it in connectable mode.
 - Make sure that the Serial Port Adapter is in transparent data mode (green light). Make sure that the Serial Port Adapter is not in configuration mode (orange light). After configuring your Serial Port Adapter, remember to exit the configuration wizard before disconnecting it from the PC.
 - If high security mode has been selected on one of the devices wanting to communicate, the two devices have to be paired with each other. Either disable security or perform pairing. Also, note that pairing is automatic during a connection setup if it is needed.
2. The Bluetooth link between my Serial Port Adapter and my selected remote peer disconnects.
 - Your Serial Port Adapter is configured to disconnect if no data is received or sent during a longer period of time. Use the configuration wizard to disable the automatic disconnect or change the value of the timer.
 - Your Serial Port Adapter is too far away from the device it is communicating with. Move the two devices closer to each other.
 3. There is no color on the LED indicator.
 - Make sure that power is connected to the Serial Port Adapter.
 4. When I search for other devices using the configuration wizard I cannot find the device I'm searching for.
 - The remote device is too far away. Move it closer to your Serial Port Adapter.
 - The remote device is not in discoverable mode. If the remote device is a Serial Port Adapter use the configuration wizard to set it in discoverable mode. If the remote device is another device, consult the manual of that device to set it in discoverable mode.

5.3 Technical Specifications

5.3.1 Environmental

Storage temperature: -30 - +85 °C

Maximum operating temperature: -30 - +85 °C

Humidity RH 5-90% non-condensing
Shock and vibration: IEC 61131-2

5.3.2 Certifications and Compliance

EMC compliance: ENV 50081-1, ENV 50081-2
Environment: IEC 61131-2
Medical: IEC 60601-01-2

5.3.3 Type Approval

FCC/CFR 47, part 15 for: RSPA333s, SPA312i
ETS 300 328,300 826

5.3.4 Radio Output Power

Model	Output Power
Serial Port Adapter 312i	7 dBm
Rugged Serial Port Adapter 333s	16.9 dBm

0 dBm = 1 mW, 4dBm = 2,5 mW, 20 dBm = 100 mW.

5.3.5 Power Supply

Model	Power Supply
Serial Port Adapter 312i	5 VDC
Rugged Serial Port Adapter 333s	8-30 VDC

5.3.6 Serial Interface

Model	Serial Interface
Serial Port Adapter 312i	RS232, male DSUB-9, 300-921600 baud, CTS/RTS flow control or no flow control.
Rugged Serial Port Adapter 333s	RS232/RS422/RS485, male DSUB-9, 300-921600 baud, CTS/RTS flow control or no flow control.

5.3.7 Housing

Model	Housing
Serial Port Adapter 312i	Plastic housing, IP20.

Rugged Serial Port Adapter 333s	Aluminum housing, IP65.
---------------------------------	-------------------------

5.3.8 Dimensions

Model	Dimensions (with x depth x height)
Serial Port Adapter 312i	63.5 x 81.5 x 25.7 mm (see 2.2.1)
Rugged Serial Port Adapter 333s	75.8 x 85.5 x 35 mm (see 2.3.1)